

## SPECIFICATIONS KOZ CABLE CLAMP TRI eco 24-35, TRI eco 33-46 and TRI eco 47-66

- Application** : suitable for fitting 3 single-conductor cables with high short-circuit load in triangular arrays
- Range** : for cables with a nominal outer diameters of 24 to 66 mm
- Material** : Polyamide, fiberglass-reinforced, black, resistance to UV rays, salt water, ozone, oils, fuels, alkalis and radioactive rays, halogen free, fully recyclable.
- Flame resistance** : UL94 V-0 and classification following DIN 5510-2:2009 with flammability class S3, smoke SR2 and dripping ST-2.
- Standards** : according to International Standard NEN-EN-IEC 61914:2009, Certificate of Conformity KOZ No 16881C by SGS.
- Flexure strength** : 210 N/mm<sup>2</sup>
- Tensile strength** : 120 N/mm<sup>2</sup>
- Thermal expansion** : 0,01% per 10° C temperature increase.
- Temperature limits** : Permanent application from -50° C to +120°. Brief heating up to 220°.
- Mechanical strength** : KOZ TRI eco 24-35: 15.000 N.  
 tested at KEMA KOZ TRI eco 33-46: 16.900 N.  
 KOZ TRI eco 47-66: 22.300 N.
- Fitting** : Central hole for TRI eco 24-33 and 33-46 is 11 mm.  
 Central hole for TRI eco 47-66 is 13 mm.
- Extra** : because of the clamps fitting-shape we have chosen to enclose the cables as much as possible, keeping the cables in place during a short circuit.

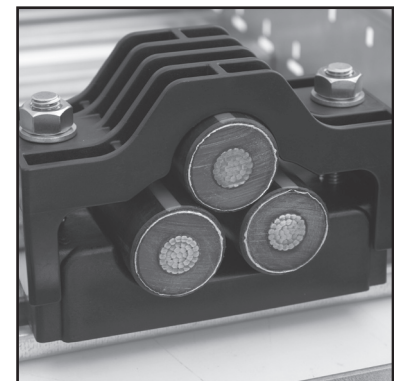
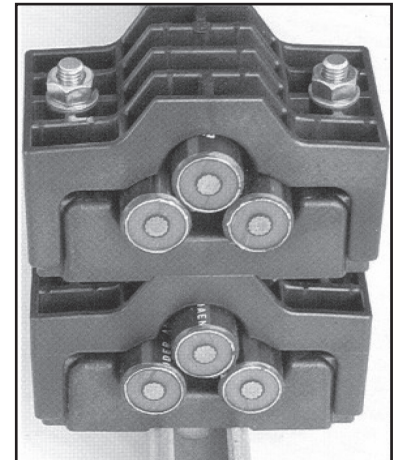

Initial torque for fastening bolts, nuts, screws : 5 – 8 Nm  
 (depends on cable manufacturer's prescription).

All tests have been done by KEMA Netherlands, SGS Belgium, Underwriters Laboratories Inc. and Schneider France.

All products listed in this catalogue are fully compliant manufactured with the EU Directive 2002/95/EG (RoHS) and Annex 2005/618/EG and 2005/717/EG. Meeting all legal obligations under REACH.

Dimensions in millimetres

Type	DØ	L	B	I	dØ	H	h	A	C	Weight/Gram
KOZ TRI eco 24-35	24-35	136	70	101	11	54-78	35	20	40	315
KOZ TRI eco 33-46	33-46	156	70	121	11	58-90	41	20	50	385
KOZ TRI eco 47-66	47-66	205	70	170	13	80-120	51	19	-	610

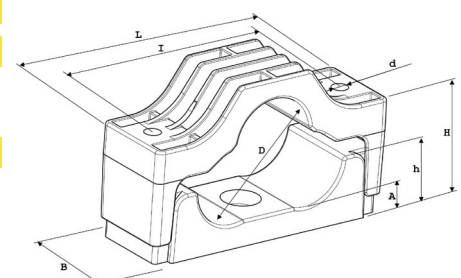
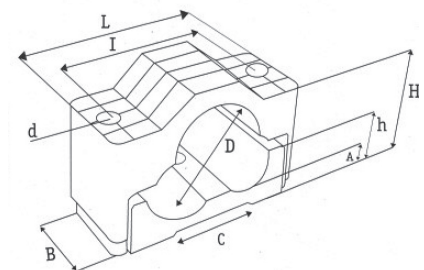

No rights may be derived from the indicated sizes, as the products re subject to ongoing development. KOZ therefore reserves the right to implement these changes without notice. For the most up-to-date information, see our Internet site: [www.kozproducts.com](http://www.kozproducts.com)